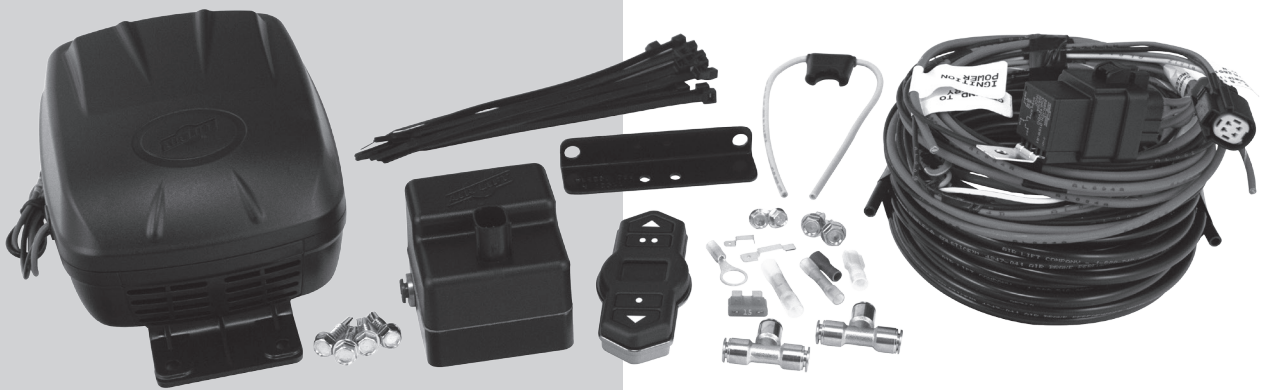


**WirelessONE™**  
by AIR LIFT®

# Kit 25870

## Key Fob-Activated Compressor System



## INSTALLATION GUIDE

For maximum effectiveness and safety, please read these instructions completely before proceeding with installation.

*Failure to read these instructions can result in an incorrect installation.*



# TABLE OF CONTENTS

<b>Introduction</b> .....	<b>2</b>
System Information .....	2
Important Safety Notice .....	2
Schematic Circuit Information .....	2
<b>Installation Schematics</b> .....	<b>3</b>
Electrical Schematic .....	3
Pneumatic Schematic .....	4
<b>Installation Diagram</b> .....	<b>5</b>
Hardware List .....	5
Tools List .....	5
<b>Installing the WirelessONE System</b> .....	<b>6</b>
Recommended Compressor Locations .....	6
Installing the Compressor .....	6
Installing the Manifold .....	7
Installing the Harness .....	8
Attaching the Air Lines .....	8
How to Remove and Install the Batteries in the Remote Control Unit .....	9
<b>Operational Modes</b> .....	<b>10</b>
Normal Mode .....	10
Settings Mode .....	10
Saving and Recalling Memory 1 .....	11
Saving and Recalling Memory 2 .....	11
Saving and Recalling Memory 3 .....	11
<b>How to Sync the Receiver to the Transmitter</b> .....	<b>12</b>
<b>Checking the System</b> .....	<b>12</b>
<b>FCC Information to User</b> .....	<b>12</b>
<b>Important: To Avoid Cold Weather Freeze-up</b> .....	<b>13</b>
<b>Drilling Template Verification</b> .....	<b>14</b>
<b>Templates</b> .....	<b>15</b>
<b>Limited Warranty and Return Policy</b> .....	<b>20</b>
<b>Replacement Information</b> .....	<b>21</b>
<b>Contact Information</b> .....	<b>21</b>

# Introduction

The purpose of this publication is to assist with the installation, maintenance and troubleshooting of the WirelessONE System.

It is important to read and understand the entire installation guide before beginning installation or performing any maintenance, service or repair. The information here includes a hardware list, step-by-step installation information, safety information and a troubleshooting guide.

Air Lift Company reserves the right to make changes and improvements to its products and publications at any time. Contact Air Lift Company at (800) 248-0892 for the latest version of this manual.

## SYSTEM INFORMATION

WirelessONE is designed for automatic digital leveling of the on-board compressor system. The kit includes a compressor, manifold, wiring harness, and wireless digital controller. The system can be used in or outside the vehicle, for adjustments in full view of the vehicle.

The wireless digital controller is a compact, battery powered unit. It also includes a clip that can be attached to the vehicle's visor. Three user-defined memory settings are provided for frequently used settings. As an added safety measure, minimum air pressures are automatically maintained. The manifold is also weather resistant for maximum life expectancy.

## IMPORTANT SAFETY NOTICE

The installation of this kit does not alter the gross vehicle weight rating (GVWR) or payload of the vehicle. Check your vehicle's owner's manual and do not exceed the maximum load listed for your vehicle.

**Gross Vehicle Weight Rating:** The maximum allowable weight of the fully loaded vehicle (including passengers and cargo). This number — along with other weight limits, as well as tire, rim size and inflation pressure data — is shown on the vehicle's Safety Compliance Certification Label.

**Payload:** The combined, maximum allowable weight of cargo and passengers that the truck is designed to carry. Payload is GVWR minus the base curb weight.

## NOTATION EXPLANATION

Hazard notations appear in various locations in this publication. Information which is highlighted by one of these notations must be observed to help minimize risk of personal injury or possible improper installation which may render the vehicle unsafe. Notes are used to help emphasize areas of procedural importance and provide helpful suggestions. The following definitions explain the use of these notations as they appear throughout this guide.

### DANGER

INDICATES IMMEDIATE HAZARDS WHICH WILL RESULT IN SEVERE PERSONAL INJURY OR DEATH.

### WARNING

INDICATES HAZARDS OR UNSAFE PRACTICES WHICH COULD RESULT IN SEVERE PERSONAL INJURY OR DEATH.

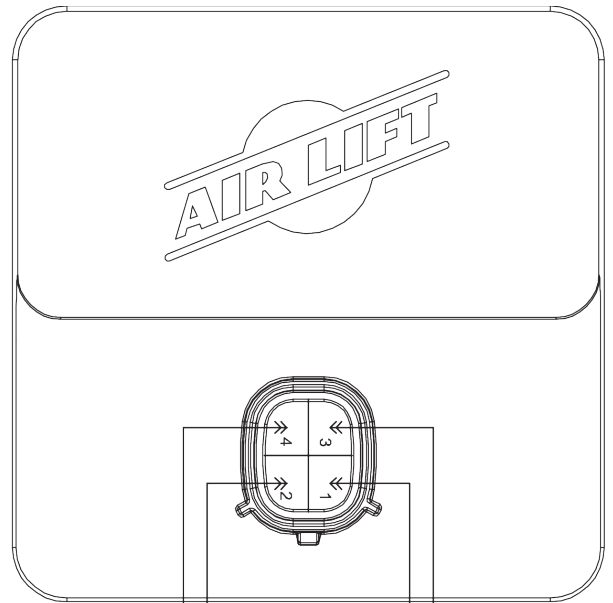
### CAUTION

INDICATES HAZARDS OR UNSAFE PRACTICES WHICH COULD RESULT IN DAMAGE TO THE MACHINE OR MINOR PERSONAL INJURY.

### NOTE

*Indicates a procedure, practice or hint which is important to highlight.*

# Installation - Electrical Schematic

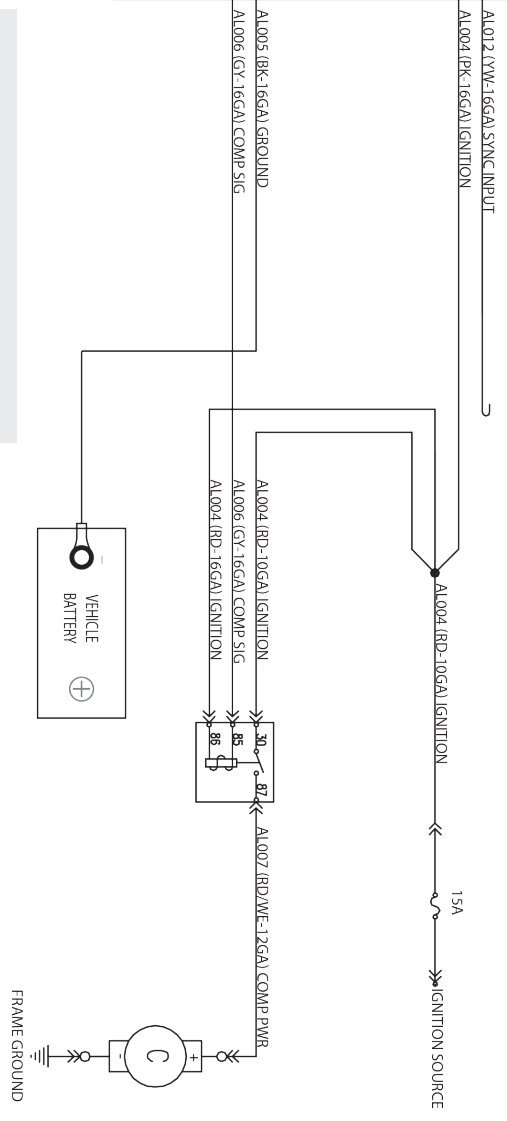


**SCHEMATIC CIRCUIT INFORMATION**

Example:

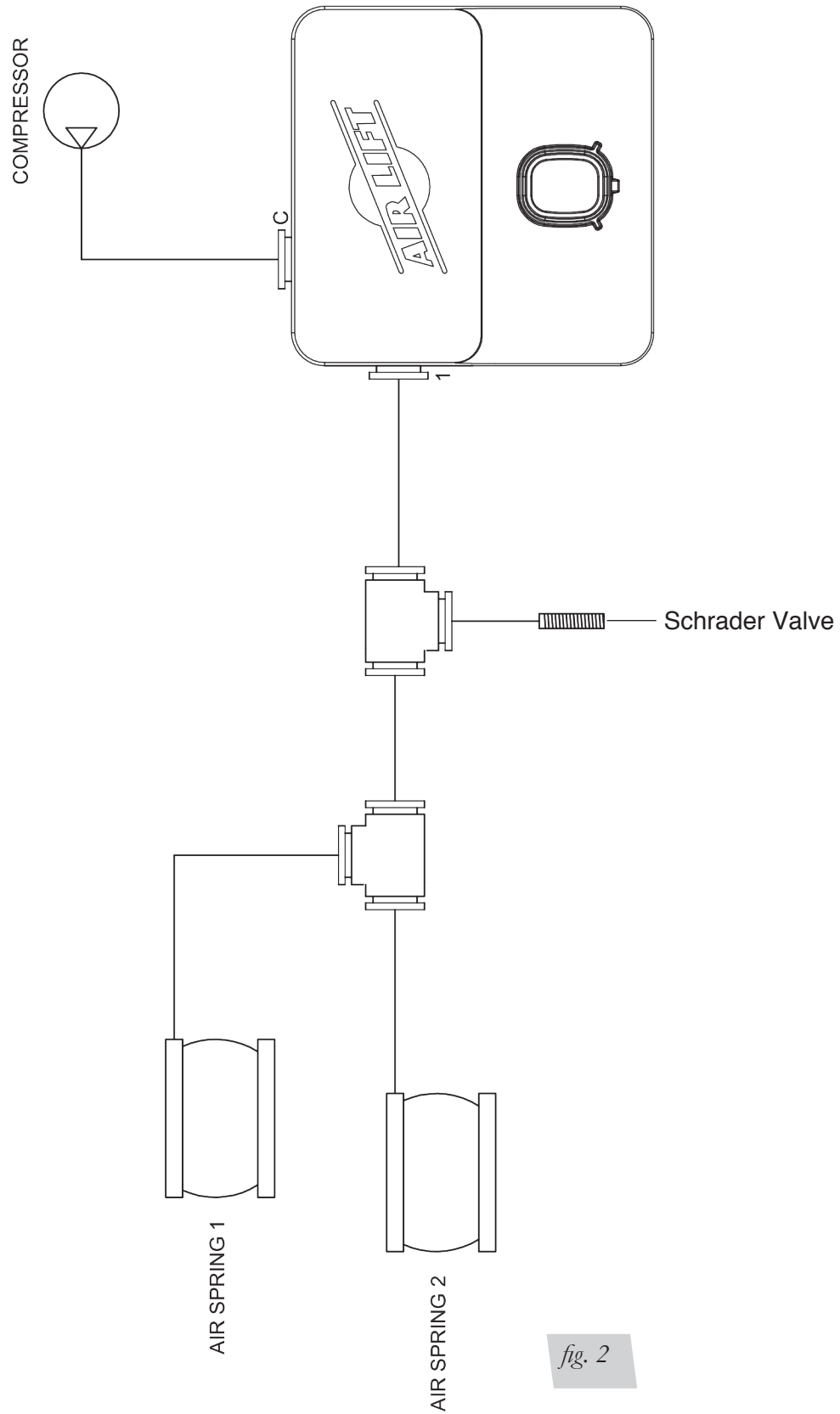
**AL004 (PK-18GA) Ignition**

●	●	●	●
Circuit Number	Wire Color (1st & Last Letter)	Wire Size	Circuit Function

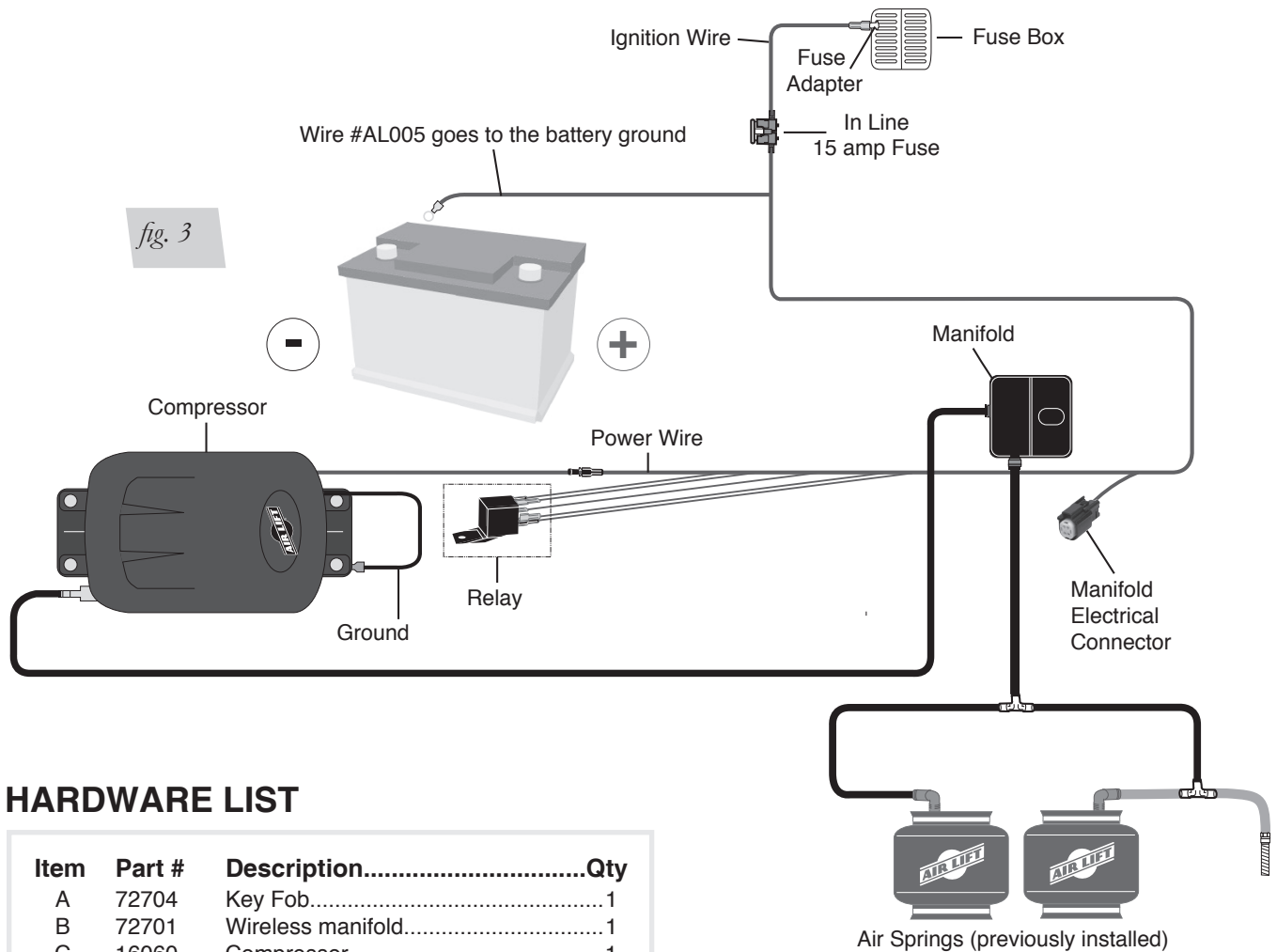


*fig. 1*

# Installation - Pneumatic Schematic



# Installation Diagram



## HARDWARE LIST

Item	Part #	Description.....Qty
A	72704	Key Fob.....1
B	72701	Wireless manifold.....1
C	16060	Compressor .....1
D	20946	20 ft. hose (1/4").....1
E	26514	Wireless manifold harness.....1
<b>Hardware Pack</b>		
F	21838	Tee 1/4 PTC .....2
G	24652	ATC fuse, spade 15A.....1
H	24561	Adapter mini fuse .....1
I	24542	1/4 ATC/ATO tap in fuse.....1
J	24595	Female spade, 12 ga .....1
<b>Item</b>	<b>Part #</b>	<b>Description.....Qty</b>
K	24524	3/16" female spade .....1
L	24661	Heat shrink butt splice 14-16 ga .....1
M	24752	Heat shrink butt splice 12-10 ga .....1
N	24539	Fuse holder ATC/ATO .....1
O	10466	8" Zip Tie.....15
P	17428	10-24 x 3/8" Slot Hex Head Screw.....2
Q	72704-012	CR2032 Battery .....2
R	11027	Bracket.....1
S	17173	#14-1/4"x3/4" Self Tapping Screws.....2
T	24681	3/8" Ring Terminal .....1

## TOOLS LIST

Description.....Qty
Hoist or floor jacks ..... 1
Safety stands ..... 2
Safety glasses ..... 1
Heavy duty drill ..... 1
#2 Phillips bit driver ..... 1
<b>Description.....Qty</b>
7/32 & 1/4 Drill bits ..... 1
5/16 Driver ..... 1
Hose cutter ..... 1
Spray bottle with dish soap/water solution ..... 1
Digital volt meter..... 1



Missing or damaged parts? Call Air Lift customer service at (800) 248-0892 for a replacement part.

# Installing the WirelessONE System

## RECOMMENDED COMPRESSOR LOCATIONS

### Important

LOCATE COMPRESSOR IN DRY, PROTECTED AREA ON VEHICLE.  
DIRECT SPLASH OR EXCESSIVE MOISTURE CAN DAMAGE  
THE COMPRESSOR AND CAUSE SYSTEM FAILURE.

Disclaimer: If you choose to mount the compressor outside the vehicle please keep in mind the compressor body must be shielded from direct splash.

#### **Please also remember...**

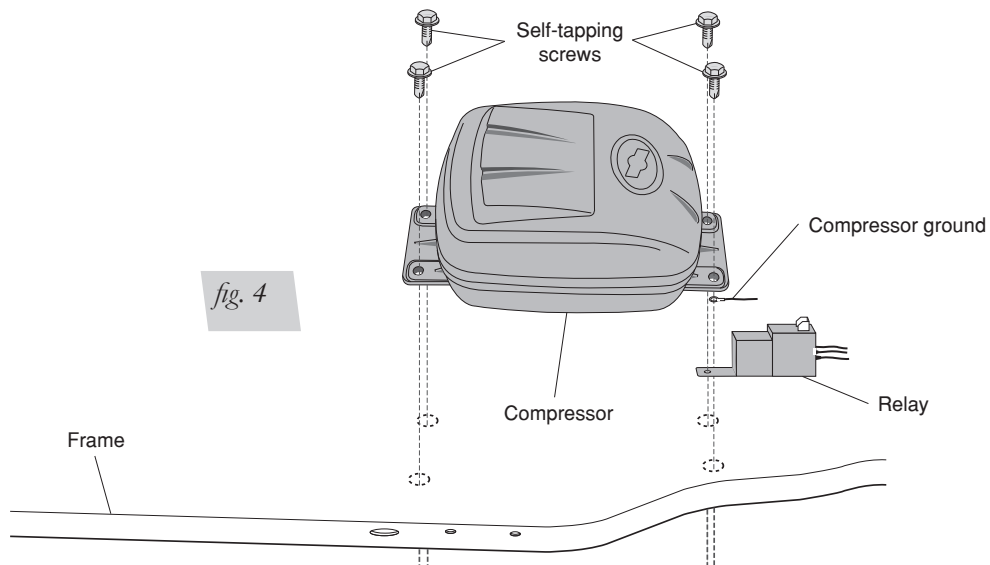
- To avoid high heat environments.
- To avoid mounting the compressor under the hood.
- To check to be sure the compressor harness #2 will reach the compressor and connect to harness #1.
- The compressor can be mounted in any position — vertical, upside down, sideways, etc. (Please refer to the instruction manual).
- Installing the compressor

## INSTALLING THE COMPRESSOR

1. Select a rigid mounting location for the compressor on the vehicles frame or crossmember (fig. 4) that shields the compressor from the elements and heat sources.

### NOTE

*The electrical harness will force the compressor to be within 24" of the manifold in order to make electrical connections.*



2. Use the supplied self tapping fasteners to fasten the compressor to the frame or cross member.
  - One of the self tapping screws will be used as an electrical ground for the compressor ring terminal.
  - Another of the self tapping screws can be used to mount the compressor relay.



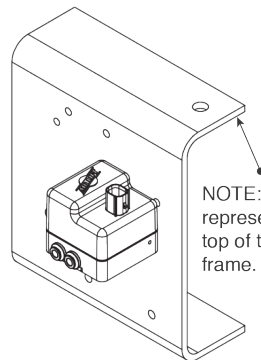
## INSTALLING THE MANIFOLD

### WARNING

IF THE USER INSTALLS THE MANIFOLD OR COMPRESSOR IN THE CAB OF THE VEHICLE IN EXTREME WEATHER CLIMATES, **DO NOT USE ANY ANTI-FREEZE PRODUCT IN THE SYSTEM AS EXHAUST FUMES CAN BE TOXIC**. CARE MUST BE TAKEN WHEN USING THIS PRODUCT! IT IS RECOMMENDED THAT THIS PRODUCT'S MSDS SHEET BE REVIEWED BEFORE USE! THIS CAN BE OBTAINED WHERE YOU PURCHASED THIS PRODUCT.

1. Select a rigid mounting location for the manifold on the vehicles frame or crossmember that shields the manifold from the elements and heat sources (fig. 5).
2. Use mounting bracket 11027 (R) to secure to the rigid mounting surface with a 17173 fastener (S). The manifold should not be the lowest point in the pneumatic system.

### Manifold Mounting:



NOTE: This represents the top of the vehicle frame.

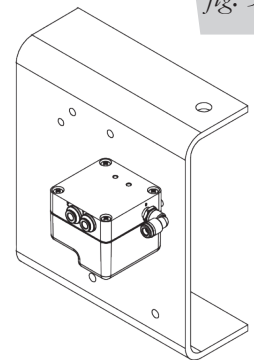
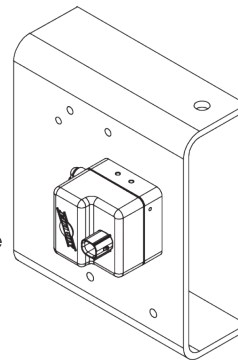


fig. 5

**PREFERRED**

**ACCEPTABLE**

**ABSOLUTELY NOT!**

## INSTALLING THE HARNESS

1. Connect electrical connector to manifold (B).
  - a. Push down until fully seated.
  - b. Push red secondary lock down.
2. Connect compressor to harness.
  - a. Cut off terminal on compressor red wire.
  - b. Strip 1/4" insulation off compressor red wire.
  - c. Crimp weatherproof blue butt splice (L) to compressor red wire.
  - d. Crimp the other end of butt splice to harness red/white wire AL007 (RD/WE-12GA).
  - e. Heat butt splice to seal connection.
  - f. Connect the compressor ground wire ring terminal and the relay to the vehicle ground (fig. 4).
    - Using a self-tapping screw for the compressor attach all the components to the vehicle frame ground.
  - g. Connect the black wire "battery ground" to the negative battery terminal after crimping terminal (T) to wire.
3. Connect the AL004 circuit to the vehicle ignition.
  - a. Route the AL004 (RD-10GA) wire to a 15A ignition source.
    - Cut off the excess wire length if all is not needed.
  - b. Strip off 1/4" insulation off both sides of the inline fuse holder (N) and the AL004 (RD-10GA) wire.
  - c. Crimp weatherproof yellow butt splice (M) to AL004 (RD-10GA) wire.
  - d. Crimp the other end of butt splice to one side of the inline fuse holder (N).
  - e. Heat butt splice to seal connection.
  - f. Select the appropriate type of fuse tap and terminal for this application (fig. 6).

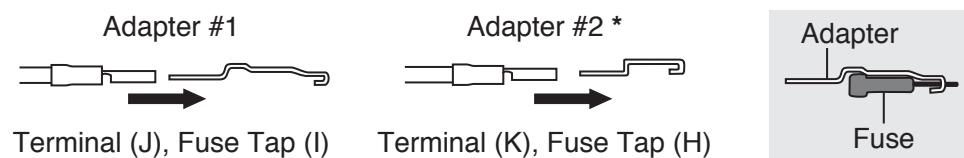


fig. 6

\* Uses 3/16" (smaller) Female Push On Connector

- g. Crimp the correct terminal that mates with the appropriate type of fuse tap for your application.
- h. Connect the terminal to the appropriate fuse tap you selected.
- i. Install fuse (G).

## ATTACHING THE AIR LINES

### Manifold to Compressor:

1. Cut a section of the 1/4" DOT air line (D) provided to go from manifold to compressor.
2. Press air line (D) over barb fitting of compressor (C).
3. Insert into "C" port of manifold (B).

### Manifold to "T-Fitting":

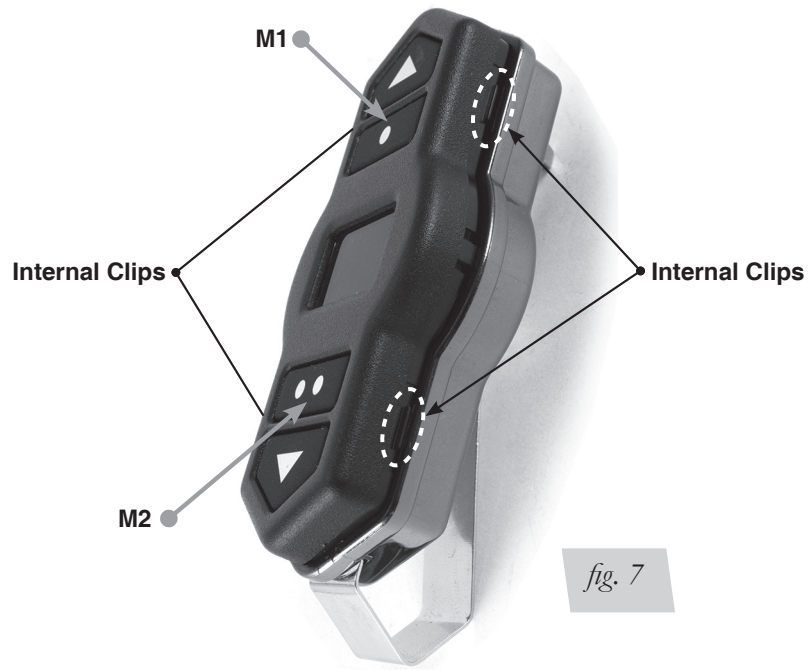
1. Cut a section of the 1/4" DOT air line (D) provided to go from manifold (B) to "T-Fitting" (F).
2. Press air line (D) into the "1" fitting of manifold (B).
3. Press other side of air line (D) into "T" fitting (F).

### "T-Fitting" to Springs:

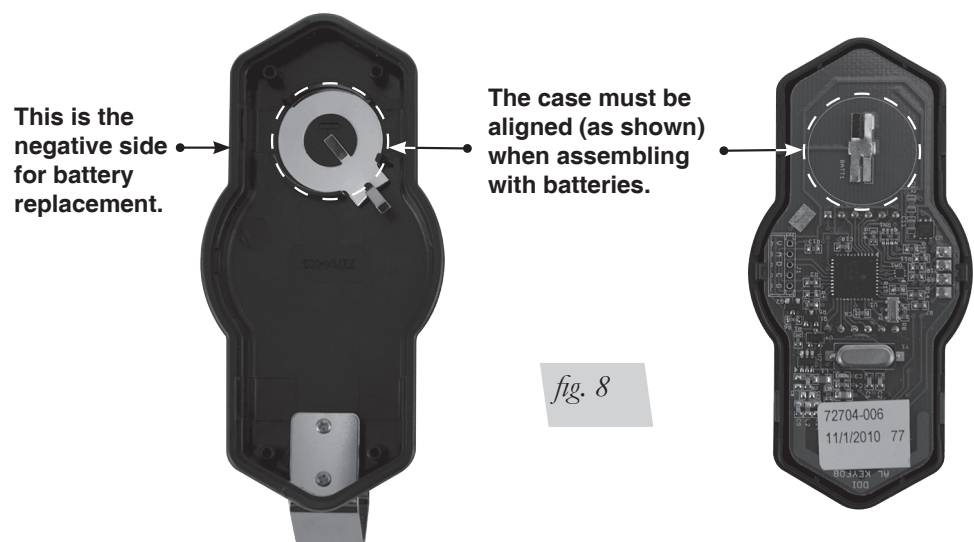
1. Cut a section of the 1/4" DOT air line (D) provided to go from "T-Fitting" (F) to Left and Right air springs.
2. Insert one side of air line (D) into "T-Fitting" (F) and the other into the air springs.

## HOW TO REMOVE AND INSTALL THE BATTERIES IN THE REMOTE CONTROL UNIT

1. To remove the two CR2032 batteries use a small flat screw driver to separate the two halves of the key fob by prying at the internal clip locations shown in figure 7.



2. Stack the two CR2032 batteries positive to negative inside the rear cover.
3. Clip the front cover and circuit board into the rear cover (fig. 8).



## OPERATIONAL MODES

**Normal Mode** : Mode in which the user can increase and decrease to the desired pressure, as well as set and recall the three memory pressures. “LB” will be displayed on startup when the battery is getting low.

**Settings Mode**: Mode in which the user can change the backlighting color, alter the unit of measure (PSI, or BAR).

### Settings Mode

1. Press and hold the up and down buttons for 5 seconds to enter the settings mode.
2. Once in the settings mode the display will display “SE” to indicate settings mode.
3. In the settings mode the M1 button (fig. 7) will scroll through all the backlighting options.
4. The M2 button (fig. 7) will toggle between the unit of measure for the pressure and display “PS” for PSI and “BA” for BAR.
5. Pressing the up and down buttons together will exit back into the Normal Mode.

### Normal Mode

#### *Increasing desired pressure:*

1. Initial press of any button will wake up display and not perform any function.
2. Upon wake up the LCD will display the desired pressure.
3. Pressing the up arrow will increment the desired pressure by 1PSI, or 0.1BAR depending on the unit of measure selected.
  - When the user releases the button the new desired pressure will be transmitted to the receiver.
4. Holding the up arrow will increment the desired pressure in units of 5PSI or 0.5BAR depending on the unit of measure selected.
  - When the user releases the button the new desired pressure will be transmitted to the receiver.
5. The maximum pressure will be 120PSI or 8.3BAR.
  - If desired pressure is max pressure then pressing the up arrow will result in no function.

#### *Decreasing desired pressure:*

1. Initial press of any button will wake up display and not perform any function.
2. Upon wake up, the LCD will display the desired pressure.
3. Pressing the down arrow will decrease the desired pressure by 1PSI, or 0.1BAR depending on the unit of measure selected.
  - When the user releases the button the new desired pressure will be transmitted to the receiver.
4. Holding the down arrow will decrease the desired pressure in units of 5PSI or 0.5BAR depending on the unit of measure selected.
  - When the user releases the button the new desired pressure will be transmitted to the receiver.
5. The minimum pressure will be 0PSI or 0 BAR.
  - If desired pressure is min pressure then pressing the down arrow will result in no function.

---

*Saving and Recalling Memory 1:*

**Recalling Memory**

- Initial press of any button will wake up display and not perform any function.
- Upon wake up the LCD will display the desired pressure.
- Press the M1 button to set the M1 pressure as the desired pressure.
- Upon the press of the M1 button the display will display “M1”.
- Once the button is released the display will display the new desired pressure and transmit the desired pressure to the receiver.

**Saving to Memory**

- With the desired pressure on the LCD, press and hold the memory button for 5 seconds to set the desired pressure to memory 1.
- While the M1 button is pressed the display will display “M1”.
- Once the desired pressure is saved to M1 the display will flash the backlight three times.

*Saving and Recalling Memory 2:*

**Recalling Memory**

- Initial press of any button will wake up display and not perform any function.
- Upon wake up the LCD will display the desired pressure.
- Press the M2 button to set the M2 pressure as the desired pressure.
- Upon the press of the M2 button the display will show “M2”.
- Once the button is released the display will display the new desired pressure and transmit the desired pressure to the receiver.

**Saving to Memory**

- Press and hold the memory button for 5 seconds to set the desired pressure to memory 2.
- While the M2 button is pressed the display will show “M2”.
- Once the desired pressure is saved to M2 the display will flash the backlight three times.

*Saving and Recalling Memory 3:*

**Recalling Memory**

- Initial press of any button will wake up display and not perform any function.
- Upon wake up the LCD will display the desired pressure.
- Press the M1 & M2 buttons to set the M3 pressure as the desired pressure.
- Upon the press of the M1 & M2 buttons the display will show “M3”.
- Once the buttons are released the display will display the new desired pressure

**Saving to Memory**

- Press and hold M1 & M2 buttons for 5 seconds to set the desired pressure to memory 3.
- While the M1 & M2 buttons is pressed the display will show “M3”.
- Once the desired pressure is saved to M3 the display will flash the backlight three times.

## HOW TO SYNC THE RECEIVER TO THE TRANSMITTER (ONLY NEEDED WITH A REPLACEMENT TRANSMITTER)

1. Turn ignition on.
2. Locate the sync wire in the wire harness.
  - It will be the yellow wire that is looped with a yellow cap around it.
3. Remove the yellow wire from the cap leaving the cap attached to the harness.
4. Disconnect power to the receiver.
  - Unplug the connector on the top.
5. Connect power to the receiver while grounding the sync input.
6. Listen for 3 clicks of the internal solenoid, then one click every second.
  - This will indicate that you are now in the “sync mode”.
  - Sync mode will last for 30 seconds total.
  - Within the 30 seconds press any button on the transmitter to send a message to the receiver.
  - Once the receiver has received a message it will sync with that transmitter and stop clicking the solenoid in 1 second intervals.
7. Reinsert the yellow wire terminal into the molded cap.

## CHECKING THE SYSTEM

1. Pressurize the system to check for leaks.
2. Inspect all air line connections with a solution of 1/5 dish soap to 4/5 water. If a leak is detected in a push-lock fitting, cut the hose end square and reinstall the air line to the fitting. Make sure the air line is cut off squarely and that the air line is completely pushed into the fitting.
3. If the compressor or the solenoid fails to function, check the 15 AMP fuse and ground connection. Repair and replace as necessary.

## FCC INFORMATION TO USER

THIS DEVICE COMPLIES WITH PART 15 OF THE FCC RULES. OPERATION IS SUBJECT TO THE FOLLOWING TWO CONDITIONS: (1) THIS DEVICE MAY NOT CAUSE HARMFUL INTERFERENCE, AND (2) THIS DEVICE MUST ACCEPT ANY INTERFERENCE RECEIVED, INCLUDING INTERFERENCE THAT MAY CAUSE UNDESIRE OPERATION.

**NOTE:** THE MANUFACTURER IS NOT RESPONSIBLE FOR ANY RADIO OR TV INTERFERENCE CAUSED BY UNAUTHORIZED MODIFICATIONS TO THIS EQUIPMENT. SUCH MODIFICATIONS COULD VOID THE USER'S AUTHORITY TO OPERATE THIS EQUIPMENT.

**FCC ID: YHT-BRM920AJM1017**

## Important

# TO AVOID COLD WEATHER FREEZE UP: ADD 4 OZ. (1/2 CUP) OF “GUNK” BRAND AIR BRAKE ANTI FREEZE

Directly into each flex member. Remove the air line and/or fitting from the air bag and fill directly. Gunk Brand Air Brake Anti-Freeze may be purchased at an automotive parts store or truck supply store.

### WARNING

IF THE USER INSTALLS THE MANIFOLD OR COMPRESSOR IN THE CAB OF THE VEHICLE IN EXTREME WEATHER CLIMATES, **DO NOT USE ANY ANTI-FREEZE PRODUCT IN THE SYSTEM AS EXHAUST FUMES CAN BE TOXIC.** CARE MUST BE TAKEN WHEN USING THIS PRODUCT! IT IS RECOMMENDED THAT THIS PRODUCT'S MSDS SHEET BE REVIEWED BEFORE USE! THIS CAN BE OBTAINED WHERE YOU PURCHASE THIS PRODUCT.

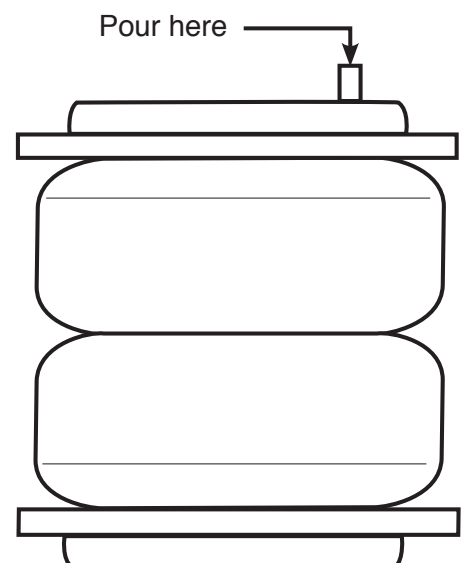
### WARNING

DO NOT FILL THROUGH COMPRESSOR OR MANIFOLD — DAMAGE WILL OCCUR.

### CAUTION

DO NOT USE ENGINE ANTI-FREEZE

Check fluid levels in flex member every year (add if needed).



## Drilling Template Verification

**CAUTION**

IMPORTANT: PRINT THIS MANUAL AT 100% SCALE. THIS MANUAL CONTAINS A DRILLING TEMPLATE, WHICH WOULD BE RENDERED INCORRECT IN DIMENSION IF PRINTED WITH ANY SCALING. USING AN INCORRECT TEMPLATE TO DRILL HOLES MAY CAUSE DAMAGE TO THE VEHICLE!

PLEASE REFER TO THE ONE-INCH SCALE (FIG. 9) AND USE A MEASURING TOOL TO CONFIRM THAT THE PRINTED SCALE MEASURES ONE INCH TO VERIFY THAT THE TEMPLATE HAS BEEN PRINTED AT 100% SCALE. IF IT IS PRINTED AT ANY SCALE OTHER THAN 100%, YOU COULD END UP DRILLING IN THE WRONG LOCATIONS ON THE VEHICLE.



# Templates

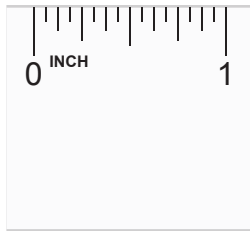
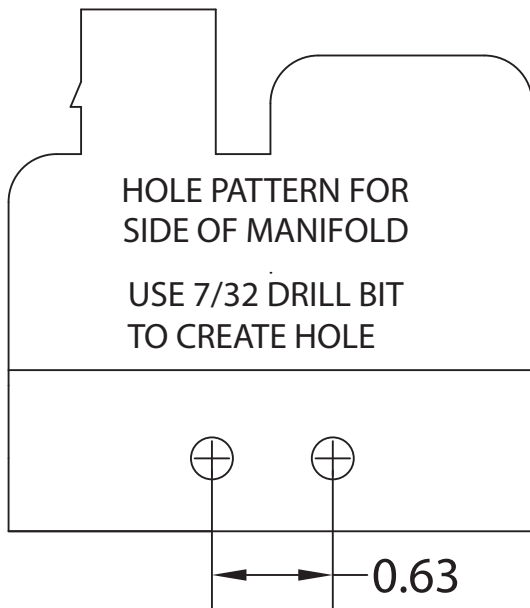
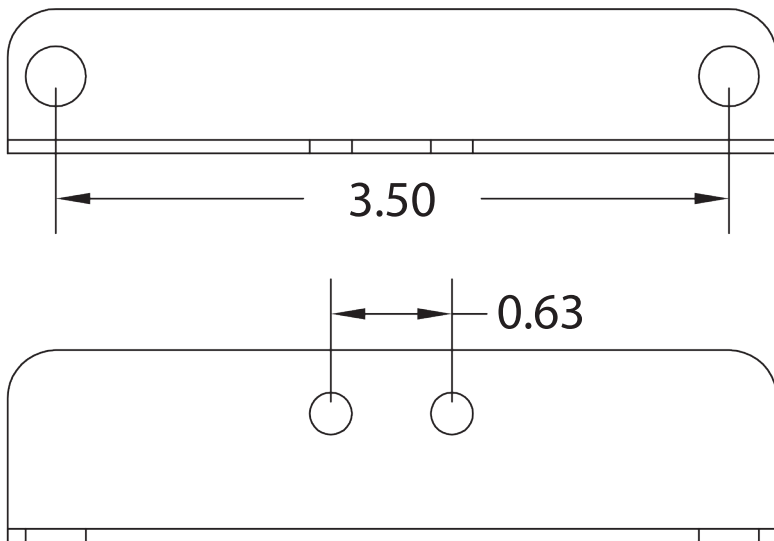


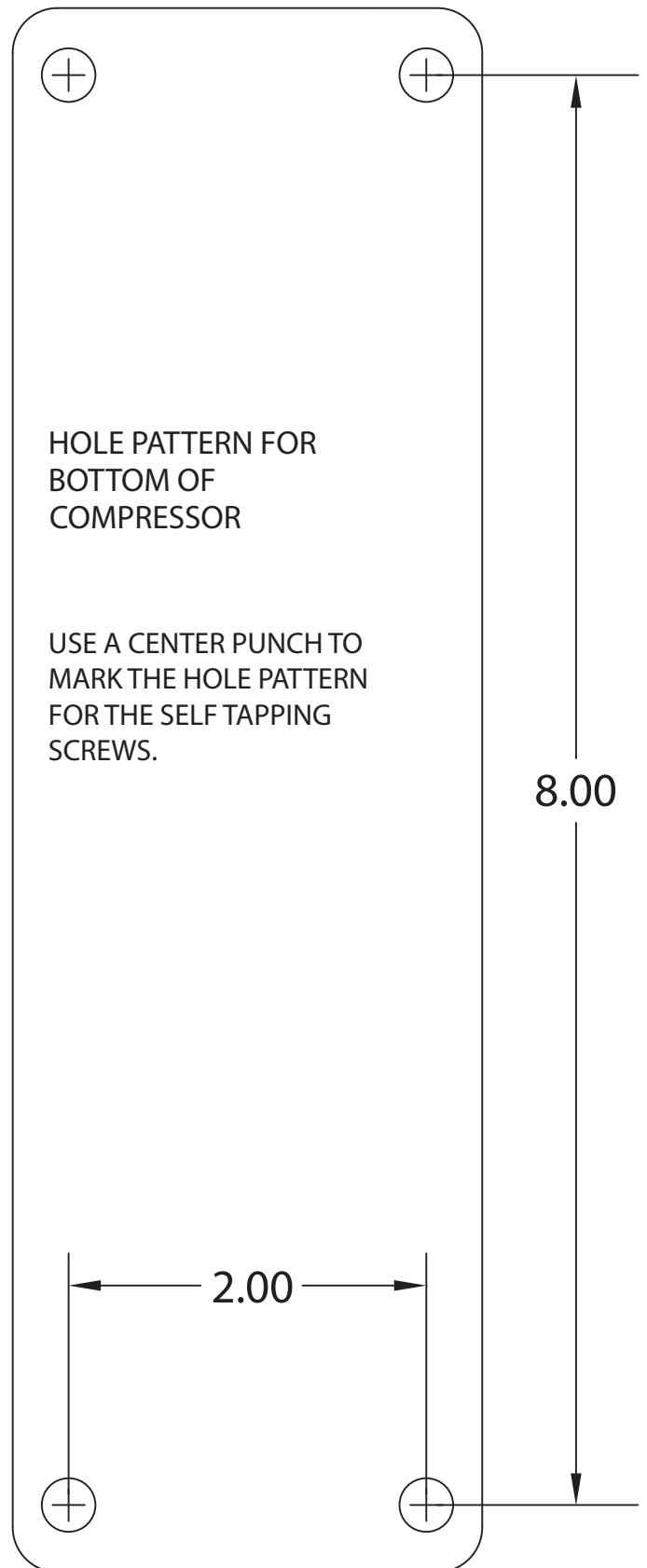
fig. 9



## 11027 Wireless bracket



# 16060 COMPRESSOR





# Notes

# Notes

# Notes

# Limited Warranty and Return Policy

## WHAT THIS WARRANTY COVERS

Air Lift Company provides a warranty to the original purchaser of its Load Support Products, for the periods of time listed below, by product line, from the date of original purchase, that the products will be free from defects in workmanship and materials when used on cars and trucks as specified by Air Lift Company and under normal operating conditions, subject to the requirements and exclusions set forth below.

## WHAT THIS WARRANTY DOES NOT COVER

The warranty does not apply to products that have been improperly applied, improperly installed, or which have not been maintained in accordance with installation instructions furnished with all products. This warranty does not apply and is void if damage or failure is caused by: accident, abuse, misuse (including but not limited to racing or off-road activities or commercial use), abnormal use, faulty installation, liquid contact, fire, earthquake or other external cause; operating the product outside Air Lift Company's instructions, specifications or guidelines; or service, alteration, maintenance or repairs performed by anyone other than Air Lift Company to the product from its purchased condition. This warranty also does not apply to: consumable parts, such as batteries; cosmetic damage, including but not limited to scratches or dents; defects caused by normal wear and tear or otherwise due to the normal aging of the product, or if any serial or identification number has been removed or defaced from the product. Air Lift Company reserves the right to change the design of any product without assuming any obligation to modify any product previously manufactured.

## LIMITATION OF LIABILITY

To the extent permitted by law, this warranty and the remedies set forth herein are exclusive and in lieu of all other warranties, remedies and conditions, whether oral, written, statutory, express or implied. AIR LIFT COMPANY DISCLAIMS ALL STATUTORY AND IMPLIED WARRANTIES, INCLUDING WITHOUT LIMITATION, WARRANTIES OF MERCHANTABILITY AND FITNESS FOR A PARTICULAR PURPOSE AND WARRANTIES AGAINST HIDDEN OR LATENT DEFECTS TO THE EXTENT PERMITTED BY LAW. To the extent such warranties cannot be disclaimed, such implied warranties shall apply only for the warranty period specified above. Please note that some states do not allow limitation on how long an implied warranty (or condition) lasts. So the above limitation may not apply to you.

Except as provided in this warranty and to the extent permitted by law, Air Lift Company shall not be liable for any direct, special, incidental or consequential damages resulting from any breach of warranty or condition, or arising in connection with the sale, use or repair of air lift products, or under any other legal theory, including but not limited to loss of use, loss of revenue, loss of actual or anticipated profits, loss of the use of money, loss of business, loss of opportunity, loss of goodwill, and loss of reputation. Air Lift Company's maximum liability shall not in any case exceed the purchase price paid by you for the Air Lift product. Please note that some states do not allow the exclusion or limitation of incidental or consequential damages, so the above limitation or exclusion may not apply to you.

## HOW TO GET SERVICE

If a defect in workmanship or materials causes your Air Lift product to become inoperable within the warranty period, before returning any defective product, call Air Lift Company at (800) 248-0892 in the U.S. and Canada (elsewhere, (517) 322-2144) to obtain a Returned Materials Authorization (RMA) number. The consumer shall be responsible for removing (labor charges) the defective product from the vehicle and returning it, shipping costs prepaid, to Air Lift Company for verification. Returns to Air Lift Company must be postage prepaid and sent to: Air Lift Company • 2727 Snow Road • Lansing, MI • 48917. You must prove to the satisfaction of Air Lift Company the date of original purchase of your Air Lift product. You must also enclose the RMA number and a return address. A minimum \$10 shipping and handling charge will apply to all warranty claims. You must also pack the product to minimize the risk of it being damaged in transit. If we receive a product in damaged condition as the result of shipping, we will notify you and you must seek a claim with the shipper.

## WHAT AIR LIFT COMPANY WILL DO

If you submit a valid claim to Air Lift Company during the warranty period, Air Lift Company will, at its option, repair your Air Lift product or furnish you with a new or rebuilt product. Air Lift Company will not reimburse you for repairs or replacement parts provided by other parties. Your repaired or replacement Air Lift product will be returned to you (subject to payment of the required warranty claim shipping and handling charge) and it will be covered under the warranty for the balance of the warranty period, if any. When a product or part is replaced, any replacement item becomes your property and the replaced item becomes property of Air Lift Company. You are responsible for installation/reinstallation (labor charges) of the product.

## HOW THE LAW RELATES TO THIS WARRANTY

This warranty gives you specific legal rights and you may also have other rights which vary from state to state. By this warranty, Air Lift Company does not limit or exclude your rights except as allowed by law. To fully understand your rights, you should consult the laws of your state.

## SPECIFIC LOAD SUPPORT WARRANTY PERIODS BY PRODUCT LINE

LoadLifter 5000™ Ultimate .....	Lifetime Limited	WirelessAIR™ .....	2 Year Limited
LoadLifter 5000™ .....	Lifetime Limited	WirelessONE™ .....	2 Year Limited
RideControl™ .....	Lifetime Limited	LoadController™ Single and Dual.....	2 Year Limited
Air Lift 1000™ .....	Lifetime Limited	LoadController™ I and II .....	2 Year Limited
AirCell™ .....	Lifetime Limited	SmartAir™ II .....	2 Year Limited
SlamAir™ .....	Lifetime Limited	Other Accessories .....	2 Year Limited

---

## Replacement Information

If you need replacement parts, contact the local dealer or call Air Lift customer service at (800) 248-0892. Most parts are immediately available and can be shipped the same day.

**Contact Air Lift Company customer service at (800) 248-0892 first if:**

- Parts are missing from the kit.
- Need technical assistance on installation or operation.
- Broken or defective parts in the kit.
- Wrong parts in the kit.
- Have a warranty claim or question.

**Contact the retailer where the kit was purchased:**

- If it is necessary to return or exchange the kit for any reason.
- If there is a problem with shipping if shipped from the retailer.
- If there is a problem with the price.

## Contact Information

If you have any questions, comments or need technical assistance contact our customer service department by calling (800) 248-0892, Monday through Friday. For calls from outside the USA or Canada, our local number is (517) 322-2144.

For inquiries by mail, our address is PO Box 80167, Lansing, MI 48908-0167. Our shipping address for returns is 2727 Snow Road, Lansing, MI 48917.

You may also contact us anytime by e-mail at [sales@airliftcompany.com](mailto:sales@airliftcompany.com) or on the web at [www.airliftcompany.com](http://www.airliftcompany.com).

## Need Help?

Contact our customer service department by calling (800) 248-0892, Monday through Friday. For calls from outside the USA or Canada, dial (517) 322-2144.

**Register your warranty online at  
[www.airliftcompany.com/warranty](http://www.airliftcompany.com/warranty)**



*Thank you for purchasing Air Lift products — the professional installer's choice!*

Air Lift Company • 2727 Snow Road • Lansing, MI 48917 or PO Box 80167 • Lansing, MI 48908-0167  
Toll Free (800) 248-0892 • Local (517) 322-2144 • Fax (517) 322-0240 • [www.airliftcompany.com](http://www.airliftcompany.com)

Printed in the USA  
JJC-0616